

Compressed Gas Gauge(511 Type)

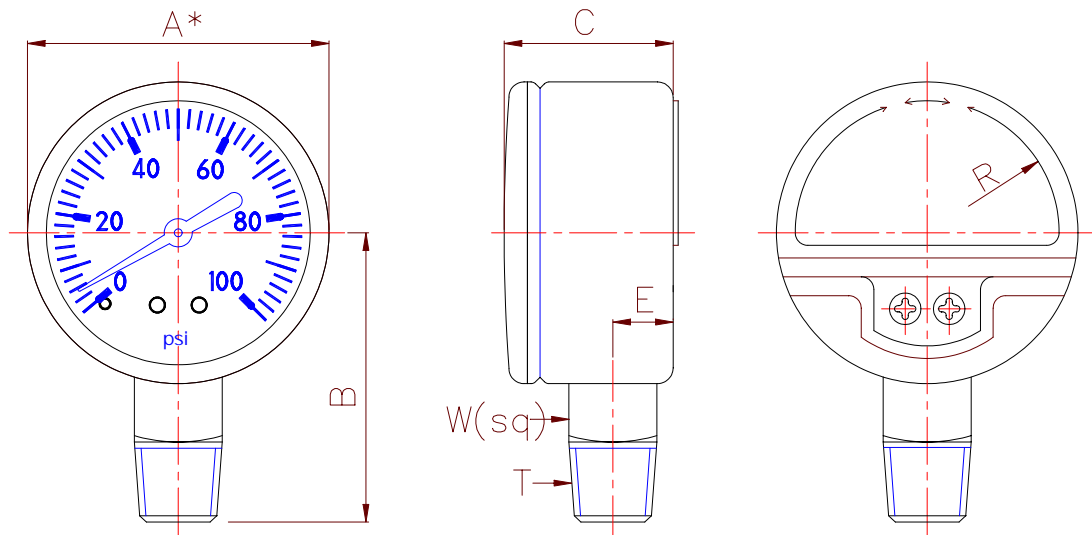

**Lower Mount
(LM)**

A* NOMINAL SIZE

A*	WEIGHT KEY	A*	B	C	C1	E	R	T	W
		mm	in						
1.5"		40.8	36.8	24.0		8.3	15.0	1/8"	11.0
		1.606	1.449	.945		.327	0.591		.433
2"		48.7	45.7	27.8		9.5	21.0	1/8" ; 1/4"	14.0
		1.917	1.799	1.095		.374	.827		.551
2-1/2"		61.6	55.7	29.7		9.5	26.0	1/8" ; 1/4"	14.0
		2.425	2.193	1.169		.374	1.024		.551

(DIMENSION CHANGE ALL RIGHTS RESERVED. BY AK.)