

ALL SST Liquid Fillable Gauge (Type 612)

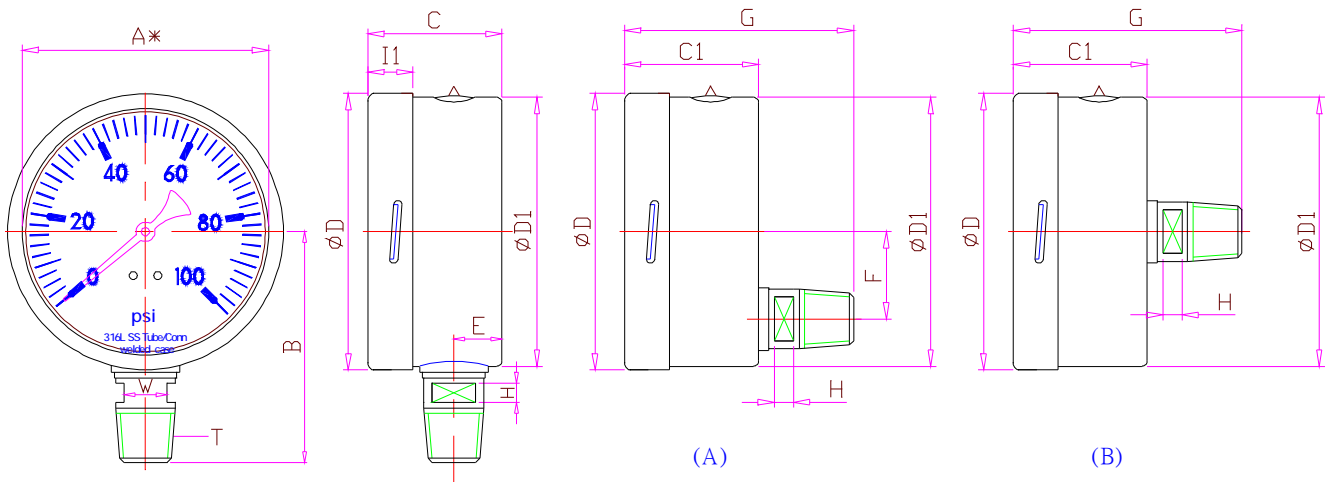

Lower Mount (LM)

Lower Back Mount (LBM)

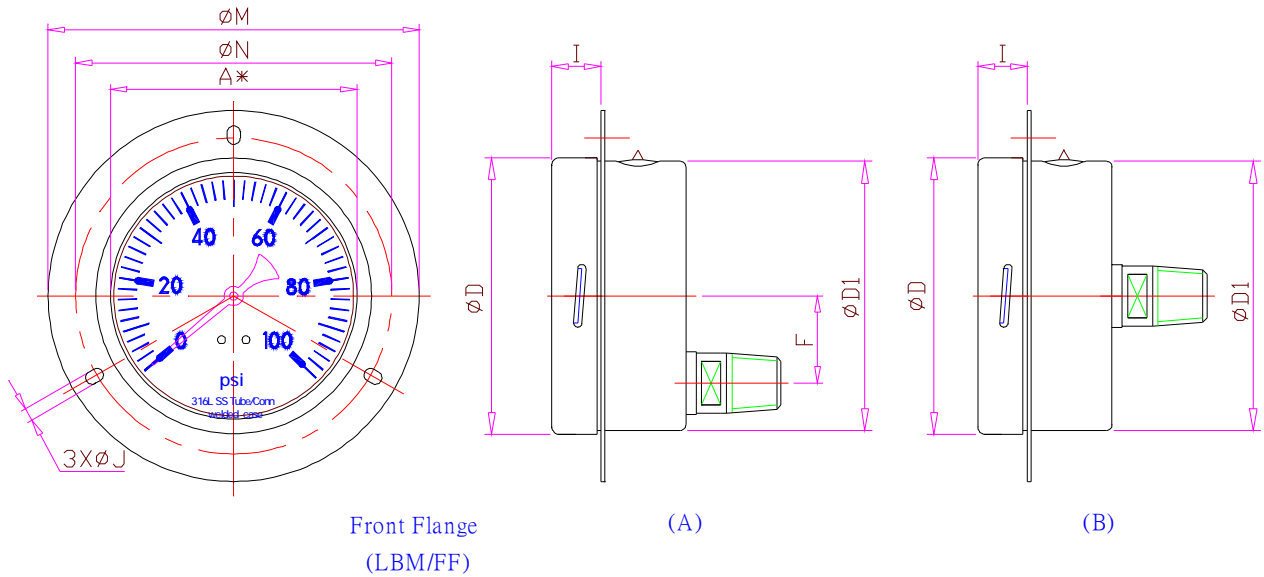

Front Flange (LBM/FF)

A* NOMINAL SIZE

A*	WEIGHT	KEY	A*	B	C	C1	D	D1	E	F	G	H	I	J	M	N	T	W	
			mm	in	mm	in	mm	in	mm	in	mm	in	mm	in	mm	in	mm	in	mm
2.5"			55.8	58.3	35.5	35.5	65.0	62.2	11.7		63.9	9.3	12.5	4.3	88.0	79.0		11.1	
			2.197	2.295	1.398	1.398	2.559	2.449	.461		2.516	.366	.492	.169	3.465	3.110		1/4"; 1/8"	.437
4"			90.2	84.6	49.0	49.3	101.6	98.8	17.1	32.0	85.1	10.0	17.5	5.5	136.3	116--118		16.7	
			3.551	3.331	1.929	1.941	4.000	3.890	.673	1.259	3.350	.394	.689	.217	5.366	4.567--4.646		1/4"; 3/8"	.657
6"			140	110	50		165	149	15.0			10.0		16.0				21.9	
			5.512	4.331	1.969		6.496	5.866	.591				.394		.630				3/8"
																		1/2"	

(DIMENSION CHANGE ALL RIGHTS RESERVED. BY AK.)