

Utility Plastic Gauge(212 Type)

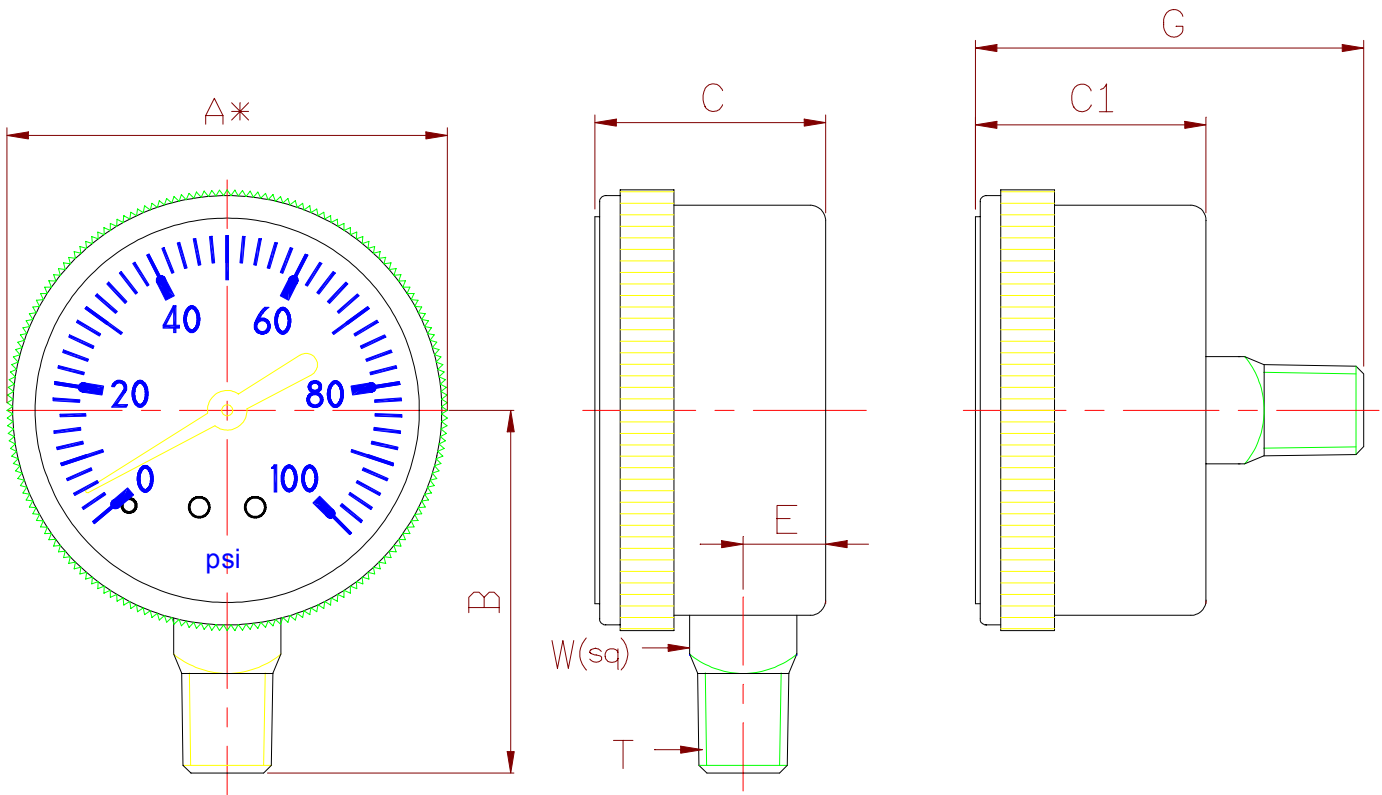

**Lower Mount
(LM)**

**Center Back Mount
(CBM)**

A*NOMINAL SIZE

2"	WEIGHT	KEY	A*	B	C	C1	E	G	T	W
			mm	57.5	47.7	30.1	29.7	10.5		
			in	2.264	1.878	1.185	1.169	.413	1.988	.551
2-1/2"	WEIGHT	KEY	A*	B	C	C1	E	G	T	W
			mm	72.0	53.2	30.4	/	11.6		
			in	2.835	2.094	1.197	/	.457	/	.551
3-1/2"	WEIGHT	KEY	A*	B	C	C1	E	G	T	W
			mm	97.8	74.6	30.2	/	10.4		
			in	3.850	2.937	1.188	/	.409	/	.551

(DIMENSION CHANGE ALL RIGHTS RESERVED. BY AK.)