

Spiral, Movementless, Utility SST Case Gauge (714A Type)

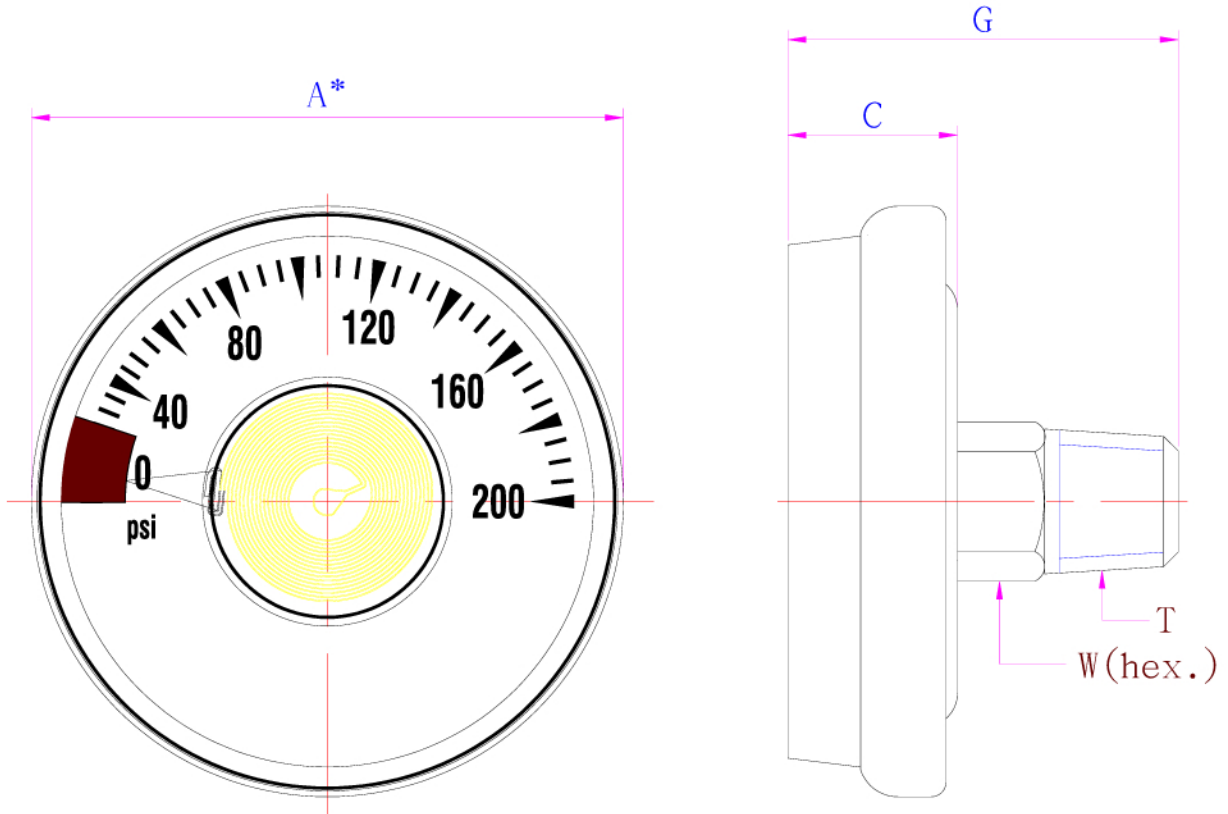

Center Back Mount
(CBM)

A* NOMINAL SIZE

	WEIGHT	KEY	A*	C	G	T	W
1.4"		mm	36.0	11.5	26.0	1/8"	11
		in	1.417	.453	1.024		.433
	WEIGHT	KEY	A*	C	G	T	W
1.6"		mm	40.8	12.5	27.7	1/8"	11
		in	1.606	.492	1.091		.433

(DIMENSION CHANGE ALL RIGHTS RESERVED. BY AK.)